SPECIFICATIONS

TO MESSRS :

ITEM : LED Lamp

MODEL : SL3-RU313T

- Contents -

- Features
- Devices
- Package Dimensions
- Absolute Maximum Ratings
- Electro-optical Characteristics
- Characteristics Diagrams
- Model Number Description
- Packing & Description
- Solder Condition
- Precaution for Use
- Reliability Test

Drawn by	Checked by	Approved by

SL3-RU313□ SERIES

Φ 3mm CYLINDER TYPE

LED LAMPS

FEATURES

- ▶ Indicator lamps
- ▶ Φ 3mm all epoxy resin mold type
- ▶ Cylinder type LED lamps
- ▶ Ultra luminous intensity

DEVICES

Model No.	Radiation Color	Lens Type	
		Epoxy Color	Diffusion
SL3-RU313T	Red	Colorless	Transparency
Material : GaAIAs/ GaAIAs(DDH)			

PACKAGE DIMENSIONS

(Unit : mm)

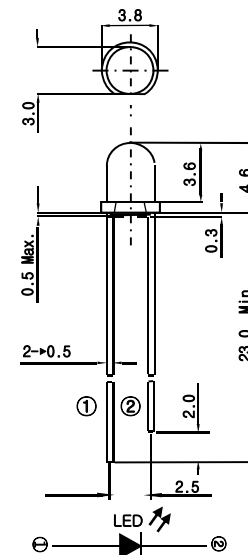

① : Anode
② : Cathode

Unspecified Tolerance : ± 0.2mm

ABSOLUTE MAXIMUM RATINGS

(Ta = 25°C)

Parameter	Symbol	Value	Unit
Power Dissipation	P_d	72	mW
Continuous Forward Current	I_F	30	mA
Peak Forward Current*1	I_{FM}	50	mA
Derating Factor(DC)	-	0.37	mA/°C
Reverse Voltage	V_R	5	V
Operating Temperature	T_{opr}	- 30 to + 85	°C
Storage Temperature	T_{stg}	- 40 to + 100	°C
Soldering Temperature*2	T_{sol}	260(within 3 seconds)	°C

*1 Duty ratio = 1/10, Pulse width = 0.1ms

*2 Soldering part of lead : up to 2mm from the body of the device

■ ELECTRO-OPTICAL CHARACTERISTICS

(Ta = 25 °C)

Parameter	Symbol	Min.	Typ.	Max.	Unit	Condition
Forward Voltage	V_F		1.8	2.4	V	$I_F=20\text{mA}$
Reverse Current	I_R			10	μA	$V_R=5\text{V}$
Luminous Intensity* ³	I_V	300	500		mcd	$I_F=20\text{mA}$
Intensity Angle	$2\theta_{1/2}$		50		deg.	$I_F=20\text{mA}$
Peak Wavelength	λ_P		660		nm	$I_F=20\text{mA}$
Spectrum Radiation Bandwidth	$\Delta\lambda$		20		nm	$I_F=20\text{mA}$
Terminal Capacitance	C_t		30		pF	$V=0\text{V}, f=1\text{MHz}$

*³ Tolerance : $\pm 30\%$

■ CHARACTERISTICS DIAGRAMS

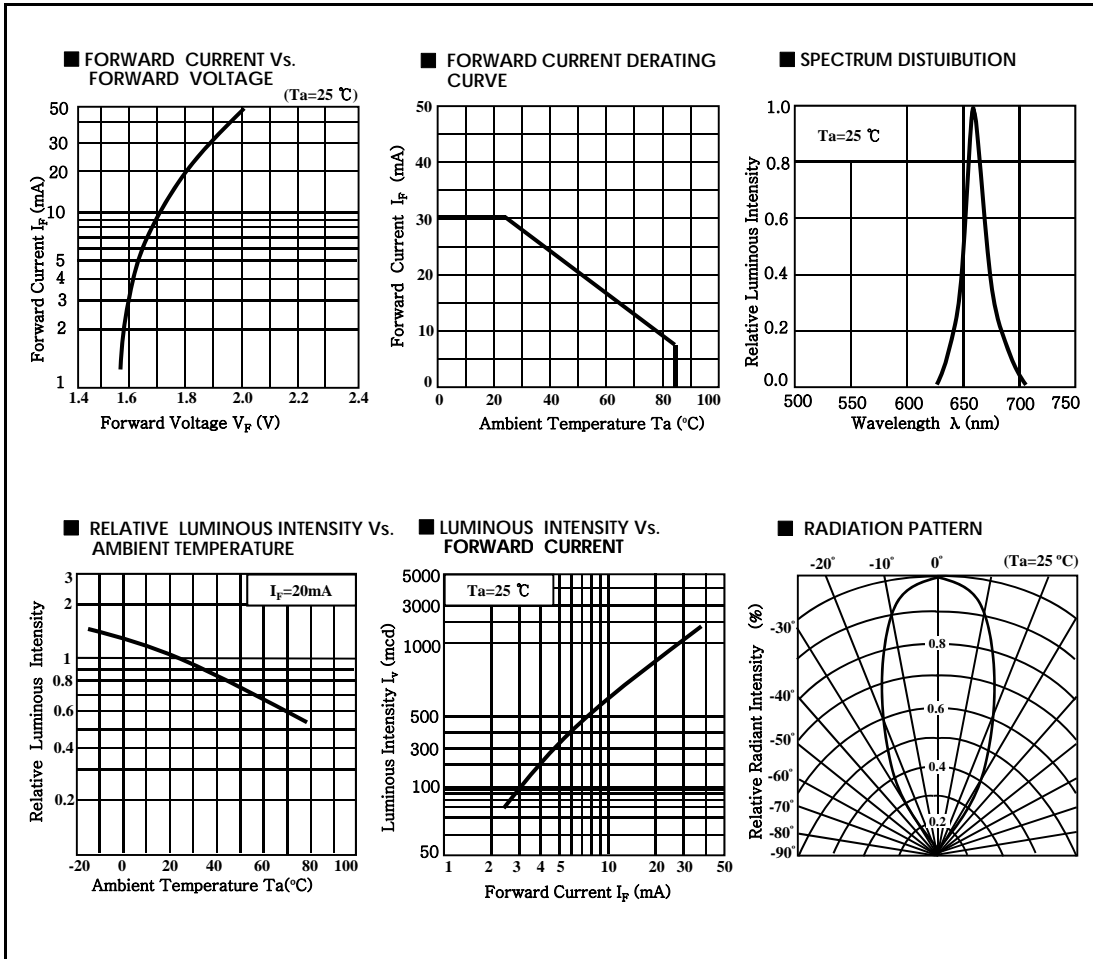

LED LAMPS

■ MODEL NUMBER DESCRIPTION

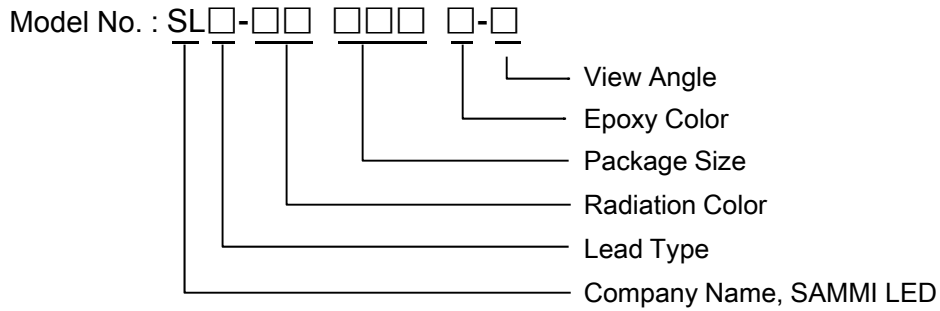

■ PACKING & DESCRIPTION

1. Inner packing : packing the vinyl pack unit at 500 pcs, and then packing inner paper box unit at 3 vinyl packs(1500 pcs)
2. Description on the paper box
 - ① Model
 - ② Lot No.
 - ③ Quantity

■ SOLDER CONDITIONS

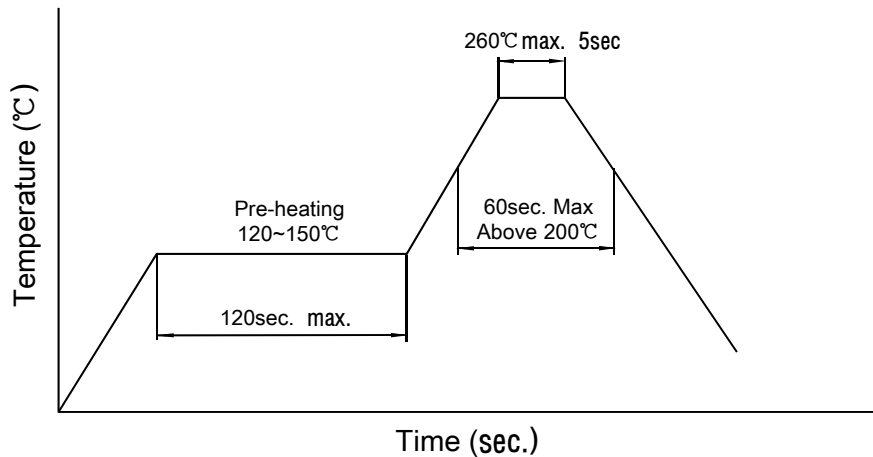

1. Preliminary heating to be at 150°C max. for 120sec max.
2. Soldering heat to be at 260°C max for 3sec.

LED LAMPS

■ PRECAUTION FOR USE

1. Avoid bending the Lead by constraint.
2. Do not soldering in condition with force to stress on the Lead.
3. Soldering flux does not contain chlorine elements against rust, and consider whether it need to be cleaning.
4. Avoid cleaning with the whole LED Lamp.
5. Use the methyl alcohol for cleaning the part of Flux soldering
 - Temperature : below 45 °C
 - Cleaning time : within 30 sec.
6. Use it within 1 week after the pack was opened.

7. Storage Instructions
 - 7-1. It is recommend to store the products in dried spot and avoid the low-temperature or high-temperature.
 - 7-2. It is recommend to avoid the spots with gas or winds affected with rust on Lead.
 - 7-3. It is recommend to avoid the direct rays of the sun.
 - 7-4. It is recommend to do not press or enforce to change quality and variation on products.

8. Static Electricity
 - 8-1. The LEDs static electricity and surge voltage damage. So it is recommended that a wrist band or anti-electro-static glove be used when handing the LEDs.
 - 8-2. All devices, equipment and machinery must be properly grounded. It is recommended that measures be taken against surge voltage to the equipment that mounts the LEDs.
 - 8-3. When inspecting the final products in which LEDs were assembled, it is recommended to check whether the assembled LEDs are damaged by static electricity or not. It is easy to find static-damaged LEDs by a light-on test or a VF test at a lower current.

9. Others
 - Regarding the detail or other questions, please contact Quality Control Management Department.

LED LAMPS

■ RELIABILITY TEST

1. Results of Reliability Test

Test Item	Test Condition	Note	Number of Damaged
Life Test	Ta=25°C, I _F =20mA	1000hrs	0/20
High Temperature Operating	Ta=85°C, I _F =5mA	1000hrs	0/20
Low Temperature Operating	Ta=-30°C, I _F =20mA	1000hrs	0/20
Thermal Shock	Ta= -30°C ~ 85°C 15sec 15sec	100 Cycle	0/20
High Temperature Storage	Ta=100°C	1000hrs	0/20
Low Temperature Storage	Ta=-40°C	1000hrs	0/20
Temperature Humidity Operating	Ta=85°C, RH=85%	1000hrs	0/20
Solder Heat	Ta= 260°C, 3sec.	1000hrs	0/20

2. Criteria for Judging the Damage

Item	Symbol	Test Condition	Limit	
			Min.	Max.
Forward Voltage	V _F	I _F =20mA		U.S.L×1.1
Reverse Current	I _R	V _R =5V		U.S.L×2.0
Luminous Intensity	I _v	I _F =20mA	L.S.L×0.7	

Notes 1. U.S.L : Upper Standard Level
2. L.S.L : Lower Standard Level