

SPECIFICATION

Device Type	Top View LED
Model	U32-1REN-05
Customer	

- Contents -

1. Outline Drawing And Dimension
2. Material Informations
3. Feature & Applications
4. Absolute Maximum Ratings
5. Initial Electrical/Optical Characteristics
6. Ranks
7. Characteristic Diagrams
8. Reliability
9. Solder Conditions
10. Taping
11. Packing Structure
12. Label Structure
13. Precaution For Use

Supplier		Customer
Written by	Approved by	Approved by

1. Outline Drawing And Dimension

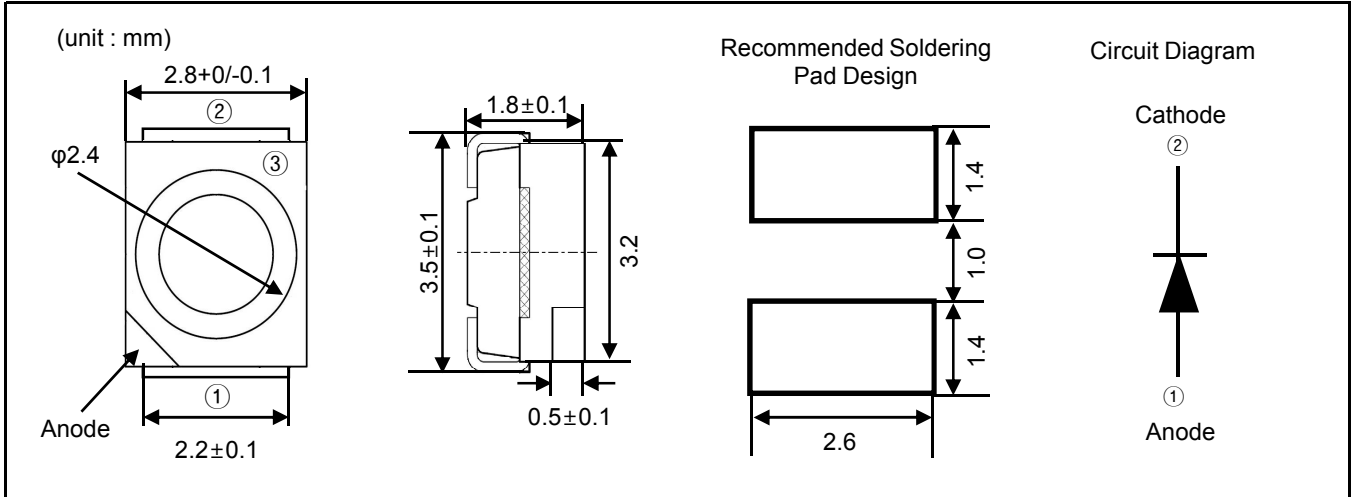

2. Material Informations

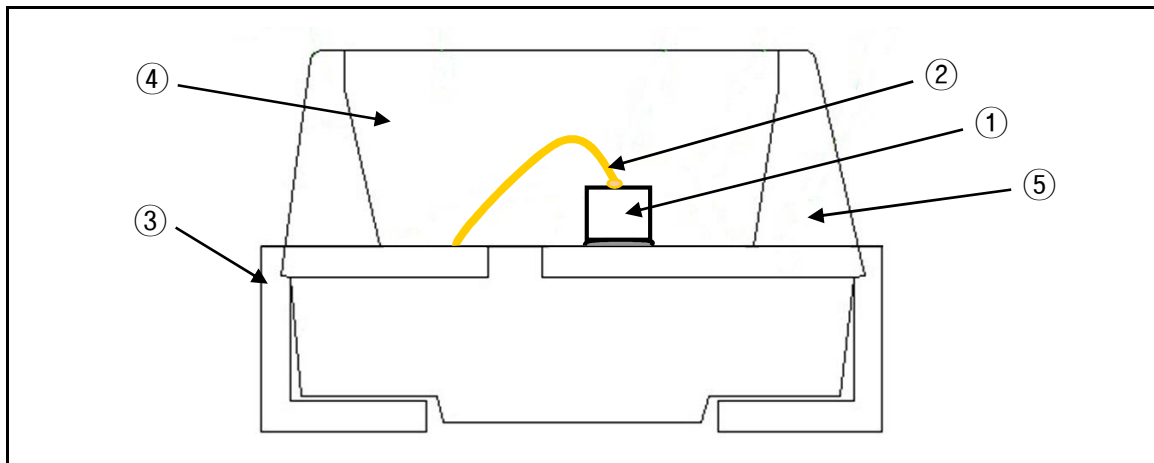

Number	Item	Material
①	Chip	AlInGaP / GaAs or AlInGaP / Si
②	Wire	Gold Wire (Au 99.99%)
③	LeadFrame	Copper Frame (Silver Plated)
④	Encapsulating Resin	Silicone
⑤	PPA Cup	Heat -Resistant Polymer

3. Feature & Applications

◆ Feature

- Package : SMD Top View Type
- 3.5 × 2.8 × 1.8 (L × W × H) Small Size Device
- Viewing Angle : $2\theta_{1/2} = 120^\circ$
- Colorless And Transparent Product
- AlInGaP/GaAs or AlInGaP/Si Chip
- Long Time Reliability

◆ Applications

- Automobile Dash Board Back Light
- Household Appliance Indicator
- Advertising/Corporate Identity/Signage Back Light
- Architectural Lighting Source
- Outdoor Lighting Source

4. Absolute Maximum Ratings

(Ta = 25°C)

Items	Symbol	Absolute Maximum Ratings	Unit
Power Dissipation	P _D	75	mW
Forward Current	I _F	30	mA
Pulse Forward Current	I _{FP}	100	mA
Operating Temperature	T _{opr}	-30 ~ +85	°C
Storage Temperature	T _{stg}	-40 ~ +100	°C
Soldering Temperature	T _{sld}	Reflow Soldering : 260°C for 10sec.	
		Hand Soldering : 350°C for 3sec.	

※ I_{FP} Conditions : Pulse Width ≤ 10msec. And Duty ≤ 1/10

5. Initial Electrical/Optical Characteristics

(Ta = 25°C)

Item	Symbol	Condition	Min.	Typ.	Max.	Unit
Forward Voltage	V _F	I _F = 20mA	-	2.0	2.5	V
Luminous Intensity	I _v	I _F = 20mA	300	-	1000	mcd
Reverse Current	I _R	V _R = 5V	-	-	10	μA
Viewing Angle	2θ _{1/2}	I _F = 20mA	-	120	-	deg.

※ Luminous intensity measurement allowance is ± 10%.

※ θ_{1/2} : The off-axis where the luminous intensity is 1/2 of the peak intensity

Note : All measurements were made under standardized environment of IST

6. Ranks

1) Dominant Wavelength Rank

(Ta = 25°C)

Rank	Test Condition	Min.	Typ.	Max.	Unit
A	I _F = 20mA	620	-	625	nm
B	I _F = 20mA	625	-	630	

※ The measurement tolerance of the dominant wavelength is ±1nm.

2) Forward Voltage Rank

(Ta = 25°C)

Rank	Test Condition	Min.	Typ.	Max.	Unit
0	I _F = 20mA	1.8	-	2.0	V
1	I _F = 20mA	2.0	-	2.2	
2	I _F = 20mA	2.2	-	2.5	

※ 0.05V tolerance for the forward voltage may be caused by measurement inaccuracy.

3) Luminous Intensity Rank

(Ta = 25°C)

Rank	Test Condition	Min.	Typ.	Max.	Unit
A	I _F = 20mA	300	-	500	mcd
B	I _F = 20mA	500	-	700	
C	I _F = 20mA	700	-	1000	

※ Luminous intensity measurement allowance is ± 10%

7. Characteristic Diagrams

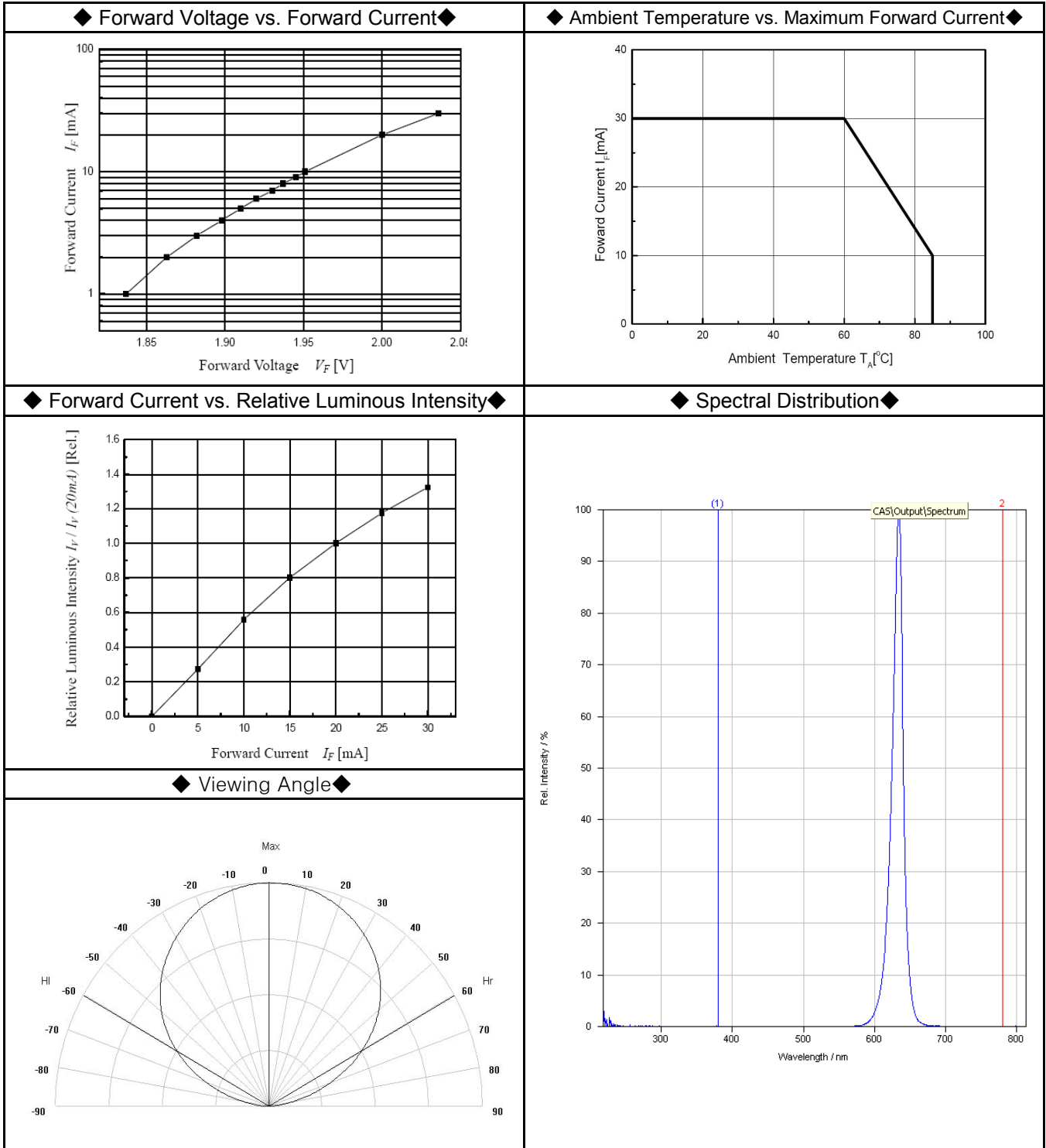

8. Reliability

Test Item	Reference	Test Conditions	Test Hours/Cycles	Number of Damage
High Temperature Storage	JEITA ED-4701	Ta = 100°C	1000 Hours	0/22
Low Temperature Storage	JEITA ED-4701	Ta = -40°C	1000 Hours	0/22
High Temperature High Humidity Storage	JEITA ED-4701	Ta = 60°C, RH = 90%	300 Hours	0/22
Temperature Cycle	JEITA ED-4701	-40°C ~ 25°C ~ 100°C ~ 25°C 30min 5min 30min 5min	100 Cycles	0/22
Resistance to Soldering Heat (Reflow Soldering)	JEITA ED-4701	Tsld = 260°C, 10sec (Pre Treatment 30°C, 70%, 168Hrs)	2 time	0/22
Solderability (Reflow Soldering)	JEITA ED-4701	Tsld = 215±5°C, 3sec (Using Flux, Lead Solder)	1 time (over 95%)	0/22
Room Temperature Life Test	Internal Reference	25°C, I _F = 20mA	500 Hours	0/22
High Temperature Life Test	Internal Reference	Ta = 100°C, I _F = 5mA	500 Hours	0/22
High Temperature High Humidity Life Test	Internal Reference	Ta = 60°C, RH = 90%, I _F = 12mA	300 Hours	0/22
Low Temperature Life Test	Internal Reference	Ta = -40°C, I _F = 20mA	500 Hours	0/22

※ Reliability Criteria

Item	Symbol	Test Condition	Limit	
			Min.	Max.
Forward Voltage	V _F	I _F = 20mA	-	U.S.L × 1.1
Luminous Intensity	I _v	I _F = 20mA	L.S.L × 0.7	-

※ U.S.L = Upper Standard Level, L.S.L = Lower Standard Level

9. Solder Conditions

1. Reflow Conditions (Lead Solder)

- Preliminary heat to be at Max. 200°C for Max. 2 mins.
- Soldering heat to be at Max. 240°C for Max. 10 secs.

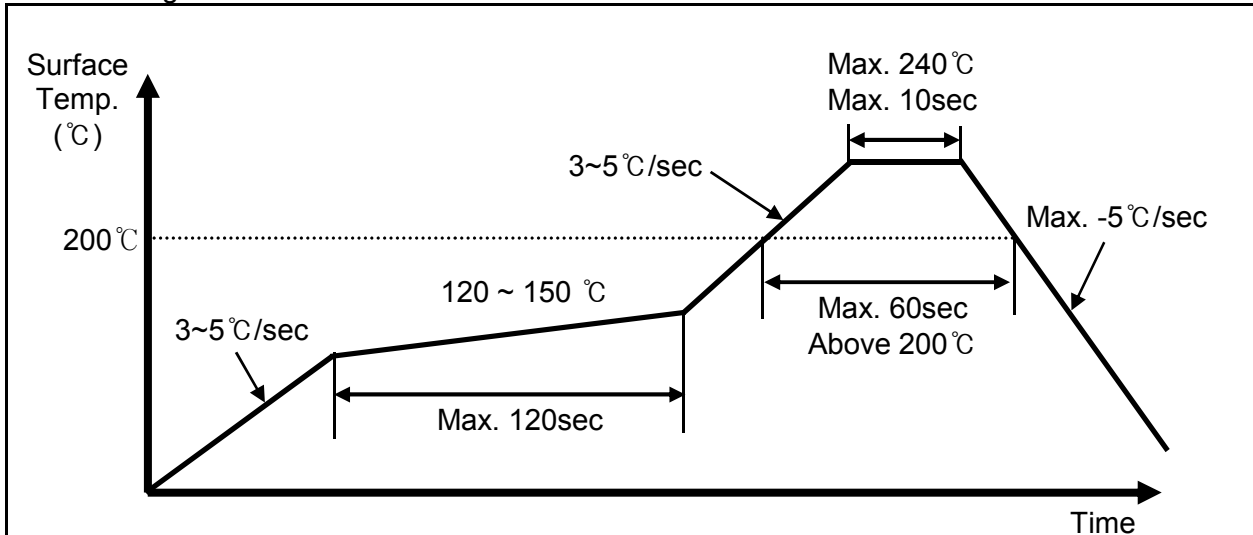

2. Reflow Conditions (Pb Free)

- Preliminary heat to be at Max. 220°C for Max. 2 mins.
- Soldering heat to be at Max. 260°C for Max. 10 secs.
- Reflow frequency : 2 times max.

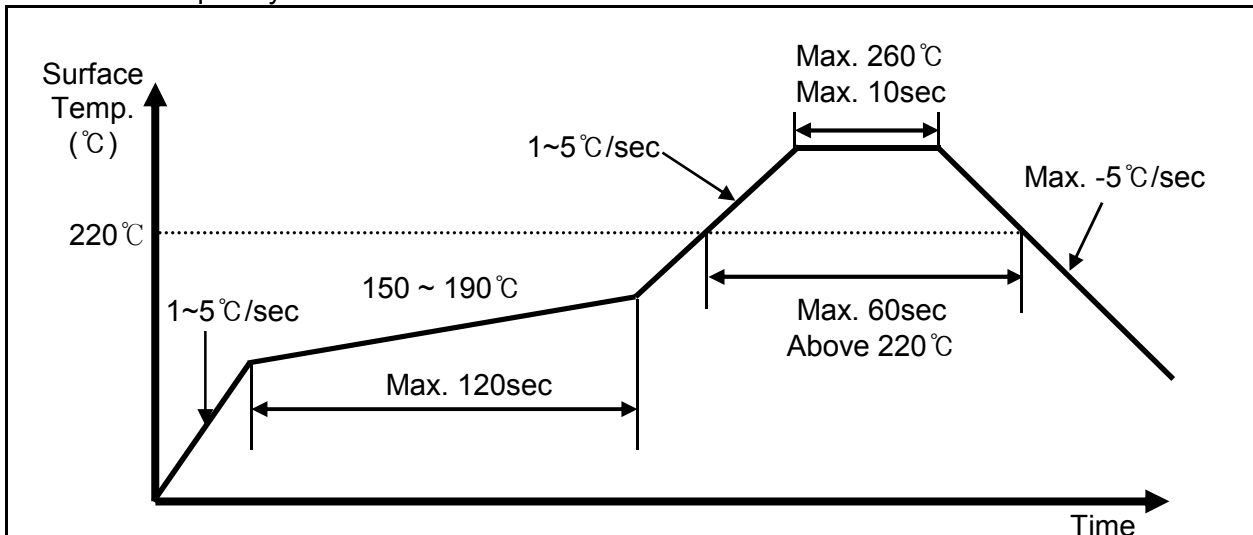

3. Hand Soldering Conditions

- Not more than 3 seconds at 350°C, under soldering iron. (One time Only)

10. Taping

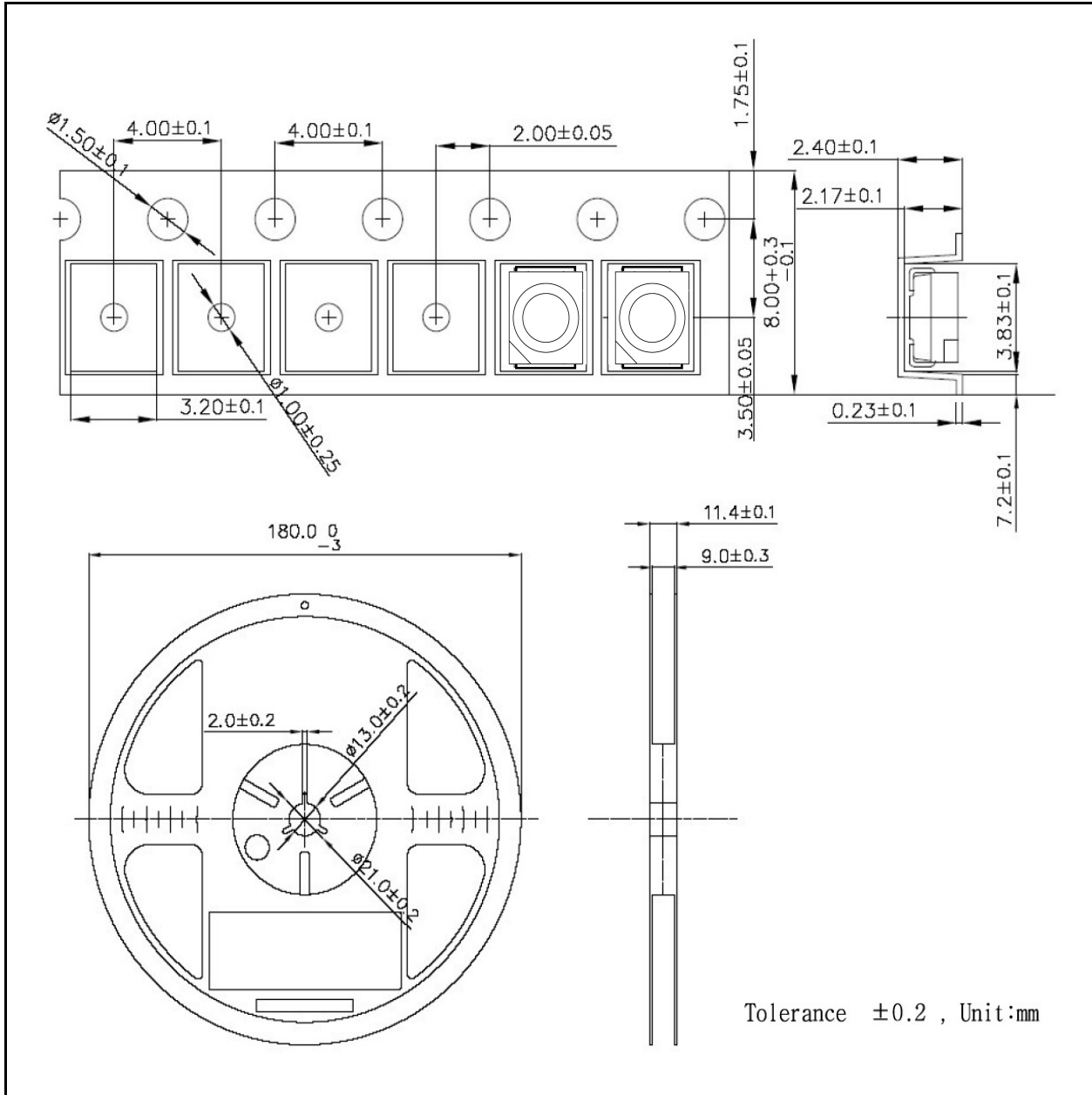

1. Quantity : The quantity/Reel to be 2,000pcs.
2. Cumulative Tolerance : Cumulative Tolerance/10 pitches to be ± 0.2 mm
3. Adhesion Strength of Cover Tape : Adhesion strength to be 0.1~0.7N when the cover tape is turned off from the carrier tape at 10° angle to be the carrier tape.
4. Packing : P/N, Manufacturing data Code No. and quantity to be indicated on a damp proof package.

11. Packing Structure

① Box Label Outlines (70 x 45 mm)

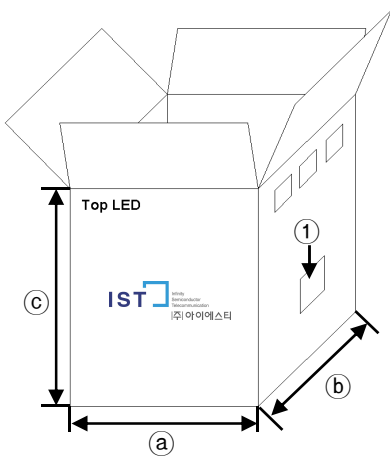
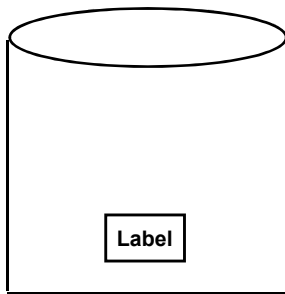
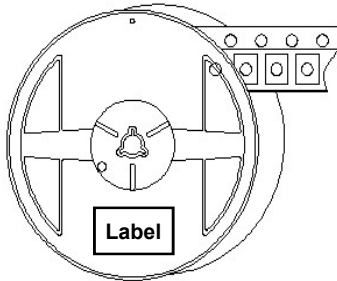

Inner Box (Max. 10Reels)



Box Structure Material : Paper (SW3B(B))

Type	Size(mm)		
	(a)	(b)	(c)
Inner	220	160	260
Oute	465	610	300

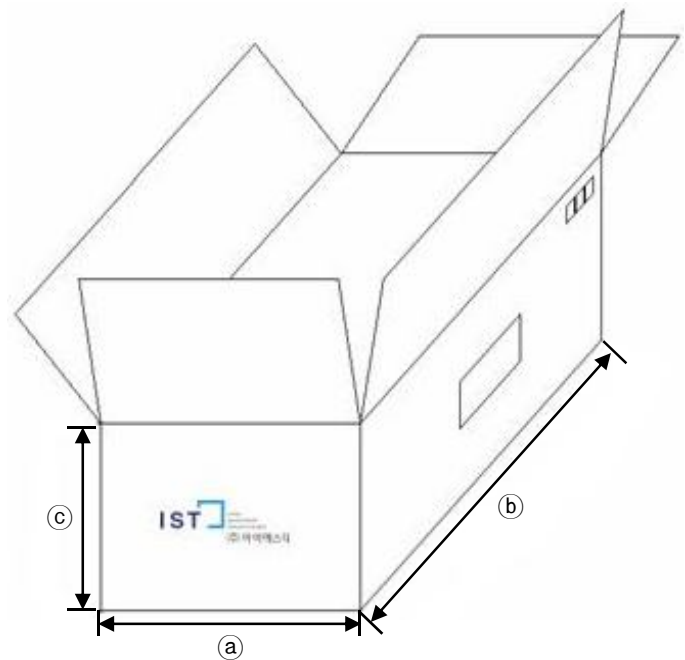

Outer Box (Max. 8 Inner Boxes)

12. Label Structure

Rank & P/N(Product Number) is composed of the following characters:

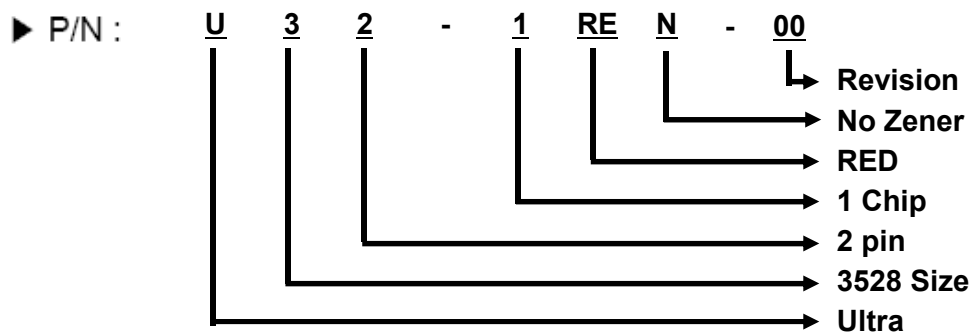
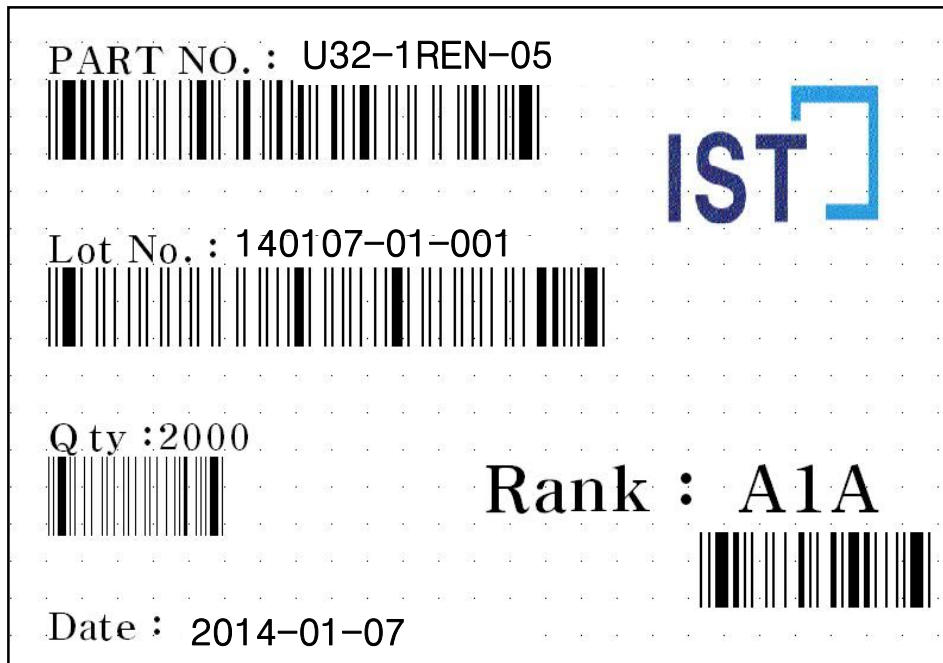
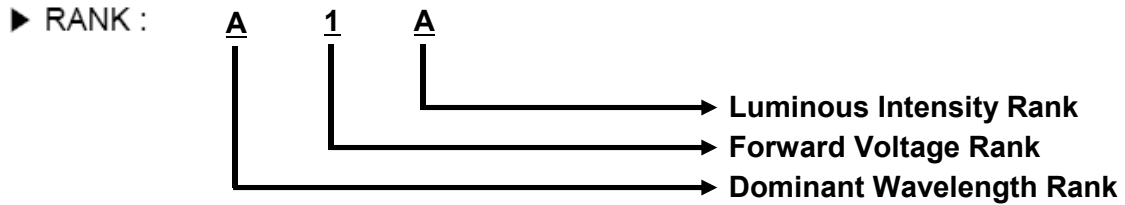

13. Precaution For Use

1. Storage

In order to avoid the absorption of moisture, it is recommended to store in a dry box (or a desiccator) with a desiccant. Otherwise, to store them in the following environment is recommended.

Temperature : 5 °C ~ 30 °C Humidity : maxim 65%RH

2. Attention after open.

LED is correspond to SMD, when LED be soldered dip, interfacial separation may affect the light transmission efficiency, causing the light intensity to drop. Attention in followed;

a. After opened and mounted the soldering shall be quickly.

b. Keeping of a fraction

Temperature : 5 ~ 40 °C Humidity : less than 30%

3. It is recommended that user should complete the use of the whole package within 48 hours upon unsealing. In the event of incomplete usage, It is advised that user preheat the remaining devices at 60±5 °C for 10-12hours prior to use.

4. Any mechanical force or any excess vibration shall not be accepted to apply during cooling process to normal temperature after soldering.

5. Quick cooling shall be avoided.

6. Components shall not be mounted on wraped direction of PCB.

7. Anti radioactive ray design is not considered for the products.

8. This device should not be used in any type of fluid such as water, oil, organic solvent, etc.
When washing is required, IPA should be used.

9. When the LEDs are illuminating, operating current should be decided after considering the ambient maximum temperature.

10. LEDs must be stored to maintain a clean atmosphere.

If the LEDs are stored for 3months or more after being shipped from IST, a sealed container with a nitrogen atmosphere should be used for storage.

11. The LEDs must be used within one day after opening the moisture proof packing. Repack unused products with anti-moisture packing, fold to close any opening and then store in a dry place

12. Repack unused products with one day after opening the moisture-proof packing.

13. The appearance and specifications of the product may be modified for improvement without notice.