

# SPECIFICATION

<b>Device Type</b>	<b>Top View LED</b>
<b>Model</b>	<b>T34-3FUN</b>
<b>Customer</b>	

## - Contents -

1. Outline Drawing And Dimension
2. Material Informations
3. Feature & Applications
4. Absolute Maximum Ratings
5. Initial Electrical/Optical Characteristics
6. Ranks
7. Characteristic Diagrams
8. Reliability
9. Solder Conditions
10. Taping
11. Packing Structure
12. Label Structure
13. Precaution For Use

<b>Supplier</b>		<b>Customer</b>
Written by	Approved by	Approved by

### 1. Outline Drawing And Dimension

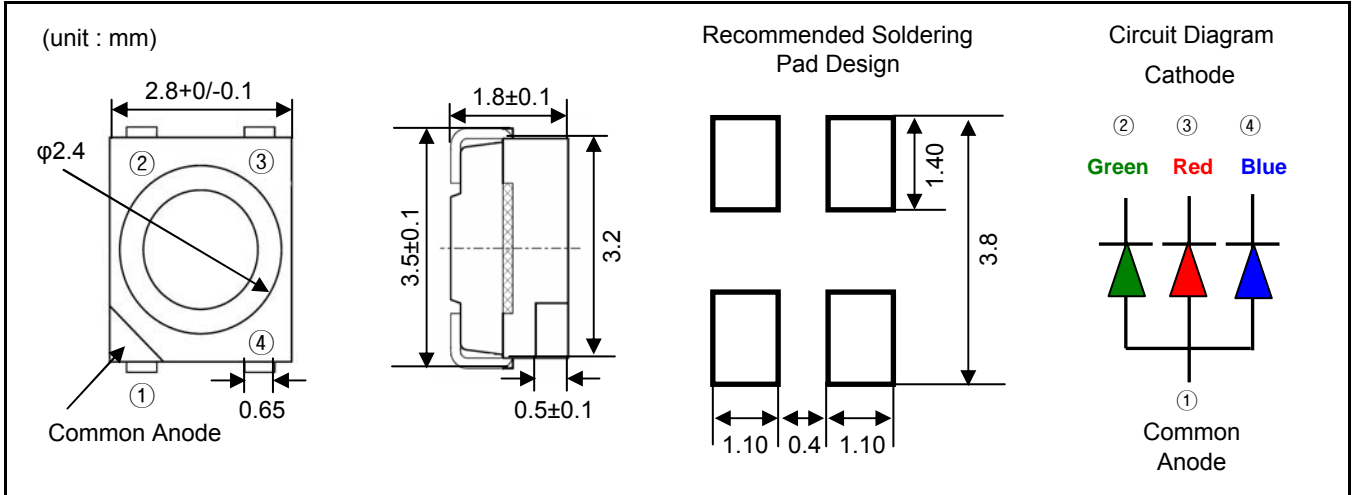

### 2. Material Informations

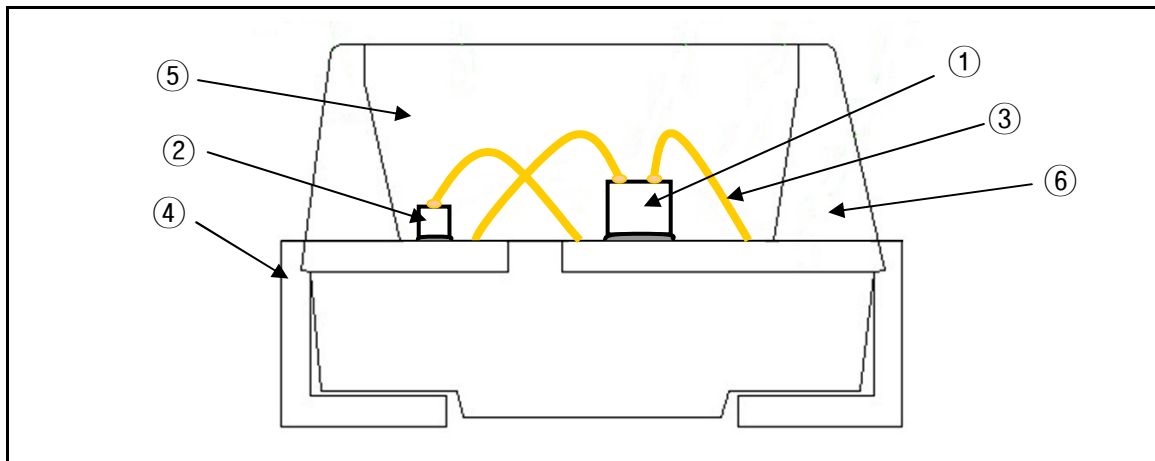

Number	Item	Material
①	Chip	InGaN (Blue, Green)
②	Chip	AlInGaP (Red)
③	Wire	Gold Wire (Au 99.99%)
④	LeadFrame	Copper Frame (Silver Plated)
⑤	Encapsulating Resin	Silicone
⑥	PPA Cup	Heat -Resistant Polymer

### 3. Feature & Applications

#### ◆ Feature

- Package : SMD Top View Type
- 3.5 × 2.8 × 1.8 (L × W × H) Small Size Device
- Viewing Angle :  $2\theta_{1/2} = 120^\circ$
- Colorless And Transparent Product
- InGaN, AlInGaP Chip
- Long Time Reliability

#### ◆ Applications

- Automobile Dash Board Back Light
- Household Appliance Indicator
- Advertising/Corporate Identity/Signage Back Light
- Architectural Lighting Source
- Outdoor Lighting Source

## 4. Absolute Maximum Ratings

(Ta = 25°C)

Items	Symbol	Absolute Maximum Ratings		Unit
Power Dissipation	P <sub>D</sub>	Red	75	mW
		Green	108	mW
		Blue	108	mW
Forward Current *1	I <sub>F</sub>	Red	30	mA
		Green	30	mA
		Blue	30	mA
Pulse Forward Current	I <sub>FP</sub>	Red	100	mA
		Green	80	mA
		Blue	80	mA
Reverse Voltage	V <sub>R</sub>	5		V
Operating Temperature	T <sub>opr</sub>	-30 ~ +85		°C
Storage Temperature	T <sub>stg</sub>	-40 ~ +100		°C
Soldering Temperature	T <sub>slid</sub>	Reflow Soldering : 260°C for 10sec.		
		Hand Soldering : 350°C for 3sec.		

\*1 IFP Conditions : Pulse Width = 10ms, Duty Ratio = 1/10

## 5. Initial Electrical/Optical Characteristics

(Ta = 25°C)

Item	Color	Symbol	Condition	Min.	Typ.	Max.	Unit
Forward Voltage ※ <sup>1</sup>	Red	V <sub>F</sub>	I <sub>F</sub> = 20mA	1.9	-	2.5	V
	Green			3.0	-	3.6	
	Blue			3.0	-	3.6	
Luminous Intensity ※ <sup>2</sup>	Red	I <sub>v</sub>	I <sub>F</sub> = 20mA	400	-	800	mcd
	Green			900	-	1500	
	Blue			200	-	400	
Dominant Wavelength	Red	λ <sub>D</sub>	I <sub>F</sub> = 20mA	618	-	630	nm
	Green			520	-	530	
	Blue			455	-	465	
Half Spectral Bandwidth	Red	Δλ	I <sub>F</sub> = 20mA	-	15	-	nm
	Green			-	25	-	
	Blue			-	25	-	
Reverse Current	Red	Δλ	V <sub>R</sub> = 5V	-	-	10	μA
	Green			-	-	10	
	Blue			-	-	10	

※<sup>1</sup> 0.05V tolerance for the forward voltage may be caused by measurement inaccuracy.

※<sup>2</sup> Luminous intensity measurement allowance is ± 10%

## 6. Ranks

### 1) Dominant Wavelength Rank

(Ta = 25°C)

Rank	Test Condition	Red	Green	Blue	Unit
A	IF = 20mA (Per Die)	618 ~ 630	520 ~ 530	455 ~ 465	nm

※ The measurement tolerance of the dominant wavelength is  $\pm 1$ nm.

### 2) Forward Voltage Rank

(Ta = 25°C)

Rank	Test Condition	Color	Min.	Max.	Unit
1	IF = 20mA (Per Die)	Red	1.9	2.5	V
		Green	3.0	3.6	
		Blue	3.0	3.6	

※ 0.05V tolerance for the forward voltage may be caused by measurement inaccuracy.

### 3) Luminous Intensity Rank

(Ta = 25°C)

Rank	Test Condition	Red	Green	Blue	Unit
A	IF = 20mA (Per Die)	400 ~ 600	900 ~ 1100	100 ~ 200	mcd
B				200 ~ 400	
C			1100 ~ 1300	100 ~ 200	
D				200 ~ 400	
E			1300 ~ 1500	100 ~ 200	
F				200 ~ 400	
G		600 ~ 800	900 ~ 1100	100 ~ 200	
H				200 ~ 400	
J			1100 ~ 1300	100 ~ 200	
K				200 ~ 400	
L			1300 ~ 1500	100 ~ 200	
M				200 ~ 400	

※ Luminous intensity measurement allowance is  $\pm 10\%$

## 7. Characteristic Diagrams

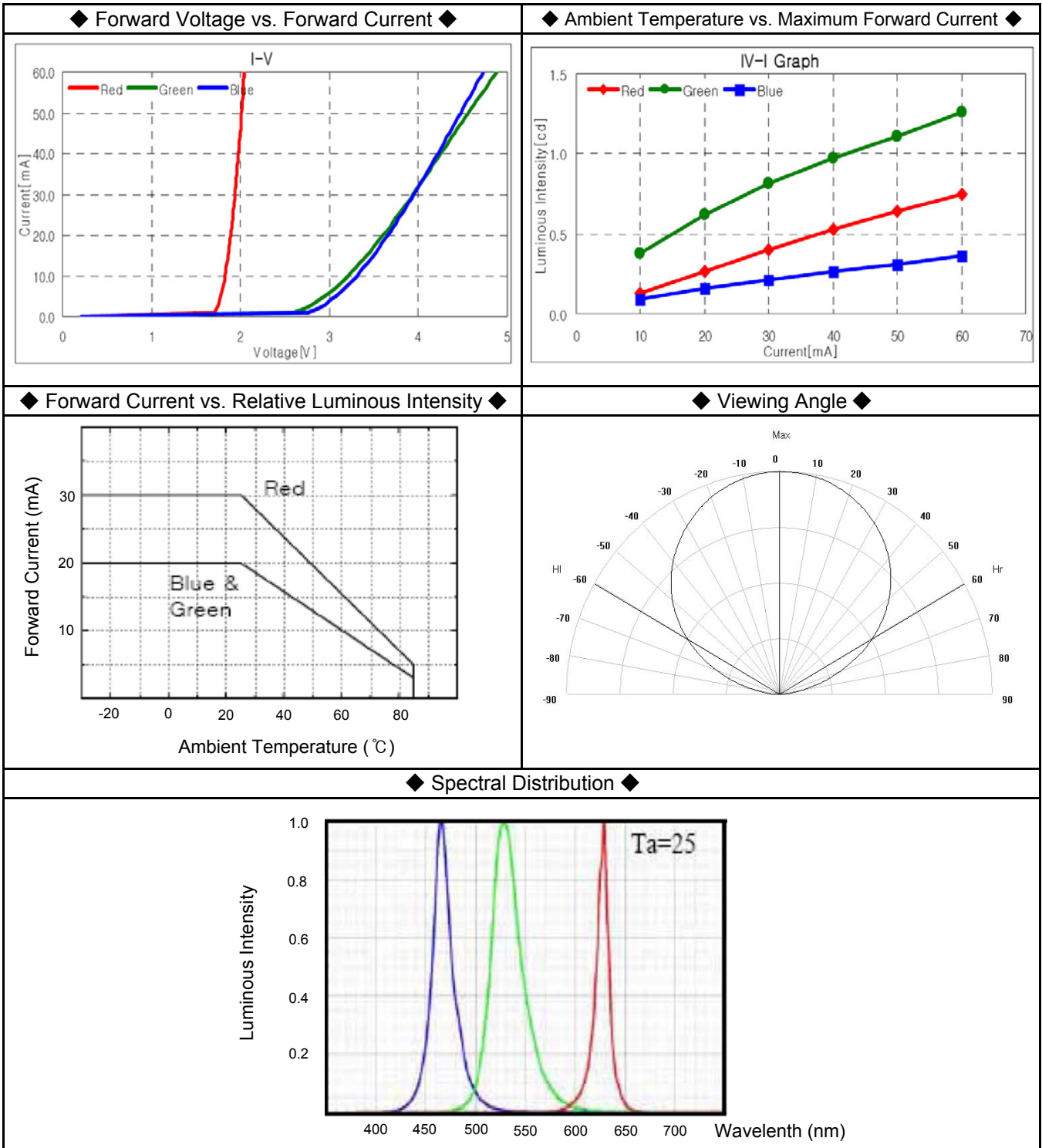

## 8. Reliability

### 1) Test Items and Results

Test Item	Test Conditions	Note (Hours/Cycles)	Number of Damaged
High Temperature Storage	Ta = 100 °C	1000 Hours	0/22
Low Temperature Storage	Ta = -40 °C	1000 Hours	0/22
High Temperature High Humidity Storage	Ta = 60 °C, RH = 90%	1000 Hours	0/22
Temperature Cycle	-40 °C ~ 25 °C ~ 100 °C ~ 25 °C 30min 5min 30min 5min	100 Cycles	0/22
Resistance to Soldering Heat (Reflow Soldering)	Tsld = 260 °C, 10sec (Pre Treatment 30 °C, 70%, 168Hrs)	2 times	0/22
Solderability (Reflow Soldering)	Tsld = 215±5 °C, 3sec (Using Flux, Lead Solder)	1 time (over 95%)	0/22
*3 Room Temperature Life Test	25 °C, I <sub>FR</sub> = 20mA, I <sub>FG</sub> = 20mA, I <sub>FB</sub> = 20mA,	1000 Hours	0/22
*3 High Temperature Life Test	Ta = 85 °C, I <sub>FR</sub> = 5mA, I <sub>FG</sub> = 5mA, I <sub>FB</sub> = 5mA,	1000 Hours	0/22
*3 High Temperature High Humidity Life Test	Ta = 60 °C, RH = 90%, I <sub>FR</sub> = 12mA, I <sub>FG</sub> = 12mA, I <sub>FB</sub> = 12mA,	1000 Hours	0/22
*3 Low Temperature Life Test	Ta = -40 °C, I <sub>FR</sub> = 20mA, I <sub>FG</sub> = 20mA, I <sub>FB</sub> = 20mA	1000 Hours	0/22

### 2) Criteria for Judging the Damage

Item	Symbol	Test Condition	Limit	
			Min.	Max.
Forward Voltage	V <sub>F</sub>	I <sub>F</sub> = 20mA (Per Die)	-	*1 U.S.L × 1.1
Luminous Intensity (1)	I <sub>V</sub>	I <sub>F</sub> = 20mA (Per Die)	*2 L.S.L × 0.7	-
Luminous Intensity (2)	I <sub>V</sub>	I <sub>F</sub> = 20mA (Per Die)	*2 L.S.L × 0.5	-

\*1 U.S.L = Upper Standard Level

\*2 L.S.L = Lower Standard Level

\*3 These test items are judged by the criteria of Luminous Intensity (2).



## 9. Solder Conditions

### 1) Reflow Conditions (Lead Solder)

- Preliminary heat to be at Max. 200°C for Max. 2 mins.
- Soldering heat to be at Max. 240°C for Max. 10 secs.

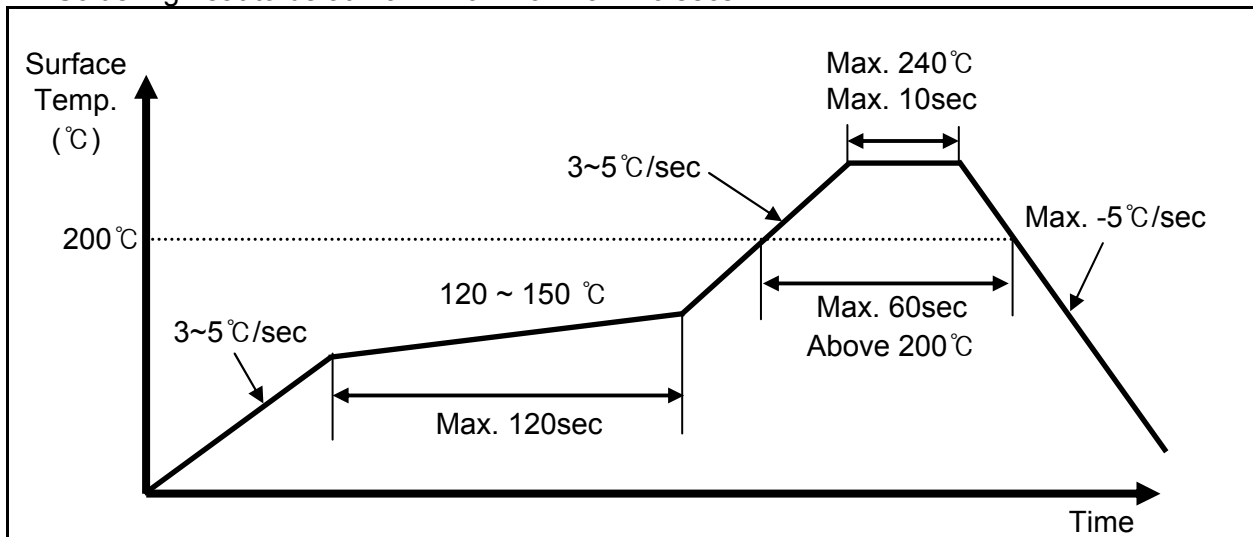

### 2) Reflow Conditions (Pb Free)

- Preliminary heat to be at Max. 220°C for Max. 2 mins.
- Soldering heat to be at Max. 260°C for Max. 10 secs.
- Reflow frequency : 2 times max.

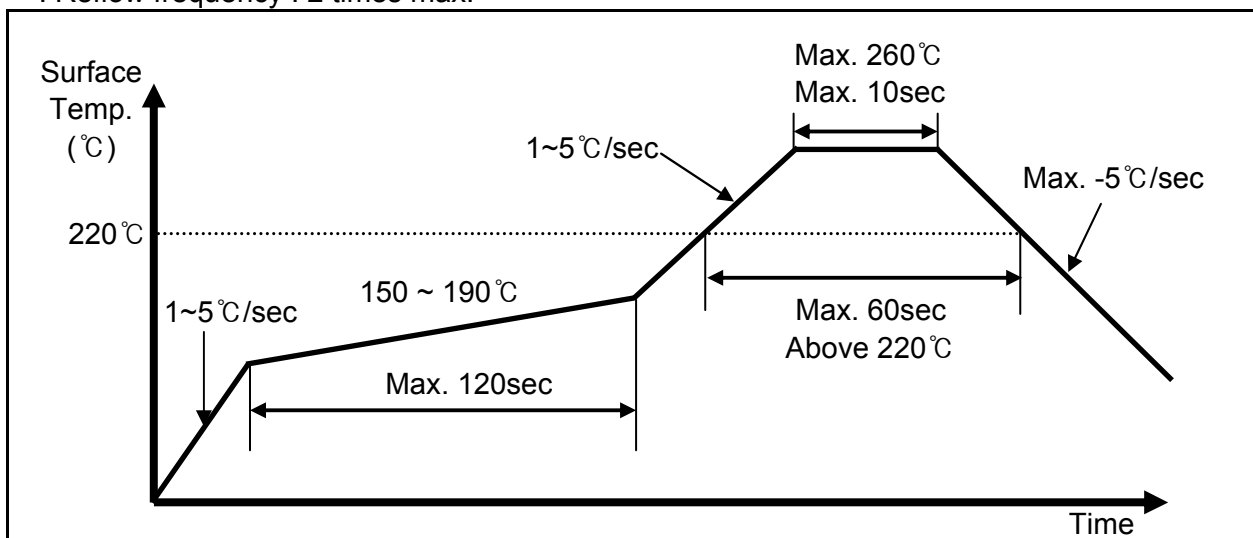

### 3) Hand Soldering Conditions

- Not more than 3 seconds at 350°C, under soldering iron. (One time Only)

## 10. Taping

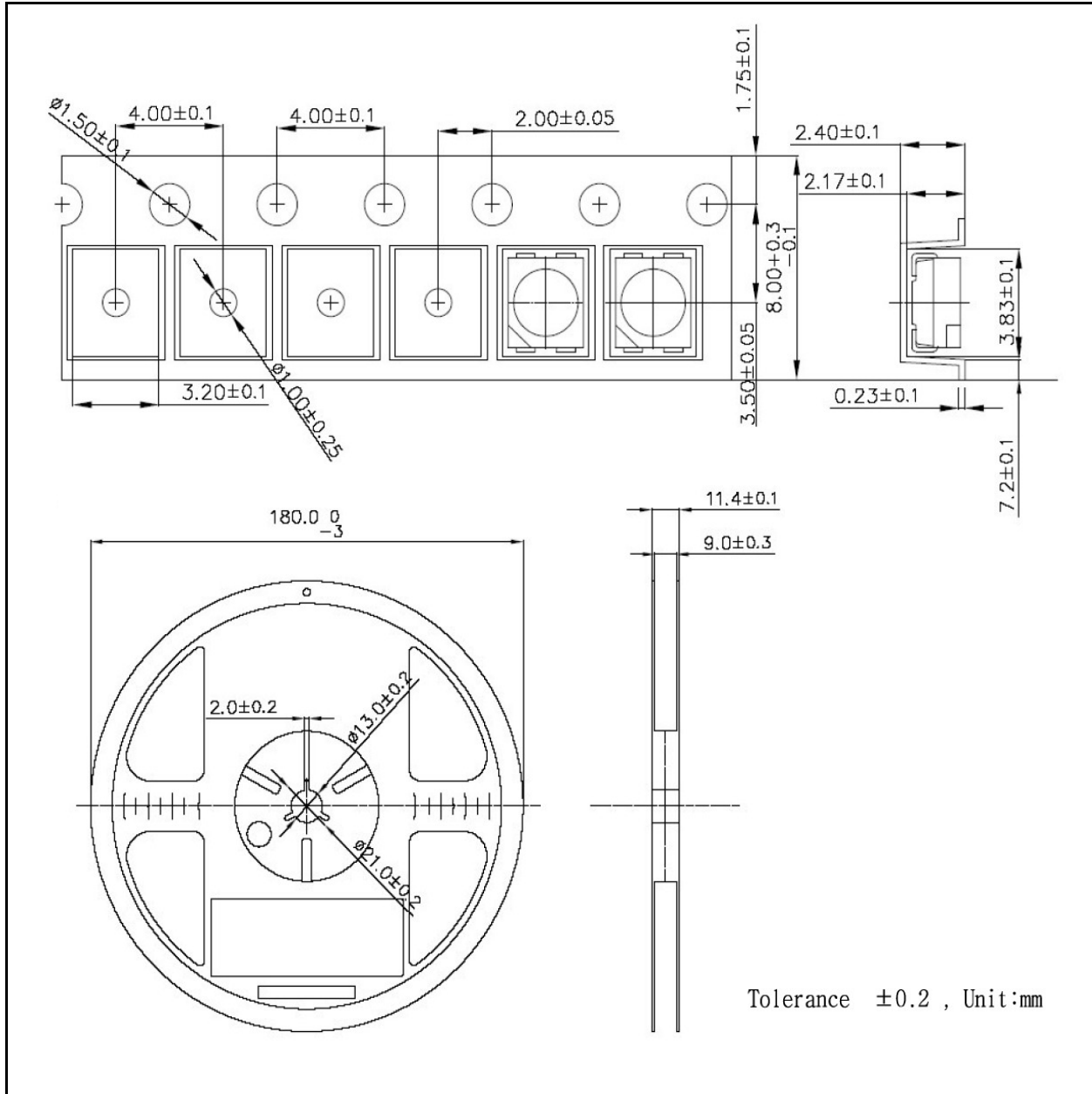

- 1) Quantity : The quantity/Reel to be 2,000pcs.
- 2) Cumulative Tolerance : Cumulative Tolerance/10 pitches to be  $\pm 0.2$ mm
- 3) Adhesion Strength of Cover Tape : Adhesion strength to be 0.1~0.7N when the cover tape is turned off from the carrier tape at  $10^\circ$  angle to be the carrier tape.
- 4) Packing : P/N, Manufacturing data Code No. and quantity to be indicated on a damp proof package.

# 11. Packing Structure

## ① Box Label Outlines (70 x 45 mm)

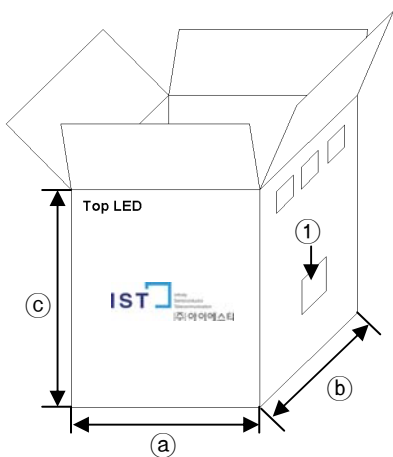
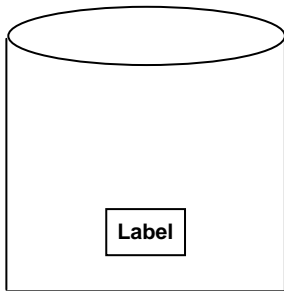
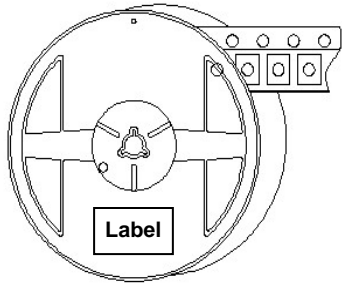

Inner Box (Max. 10Reels)

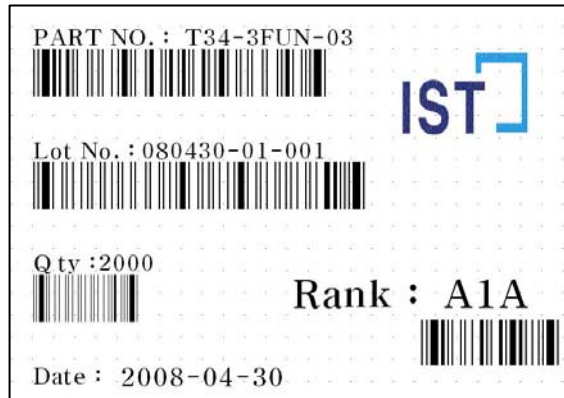

### Box Structure Material : Paper (SW3B(B))

Type	Size(mm)		
	(a)	(b)	(c)
Inner	220	160	260
Outer	465	610	300

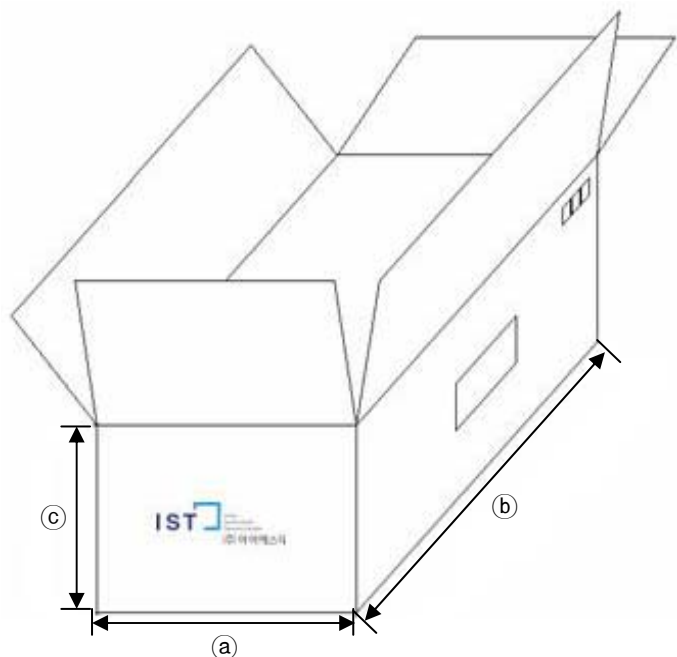

Outer Box (Max. 8 Inner Boxes)

## 12. Label Structure

Rank & P/N(Product Number) is composed of the following characters:

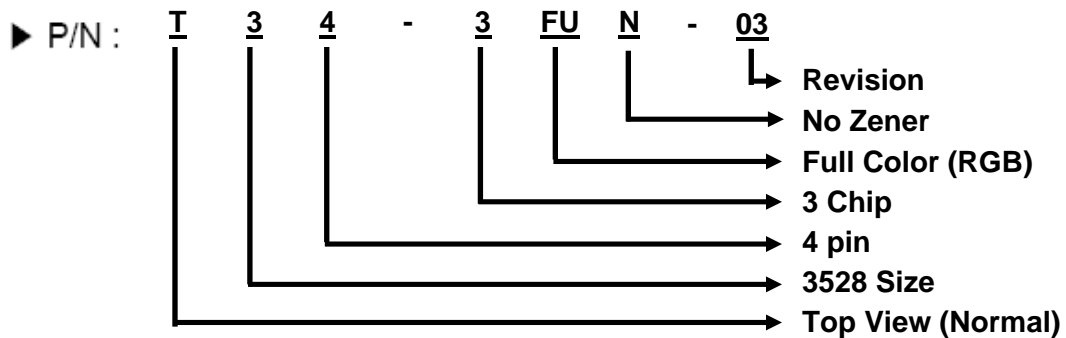
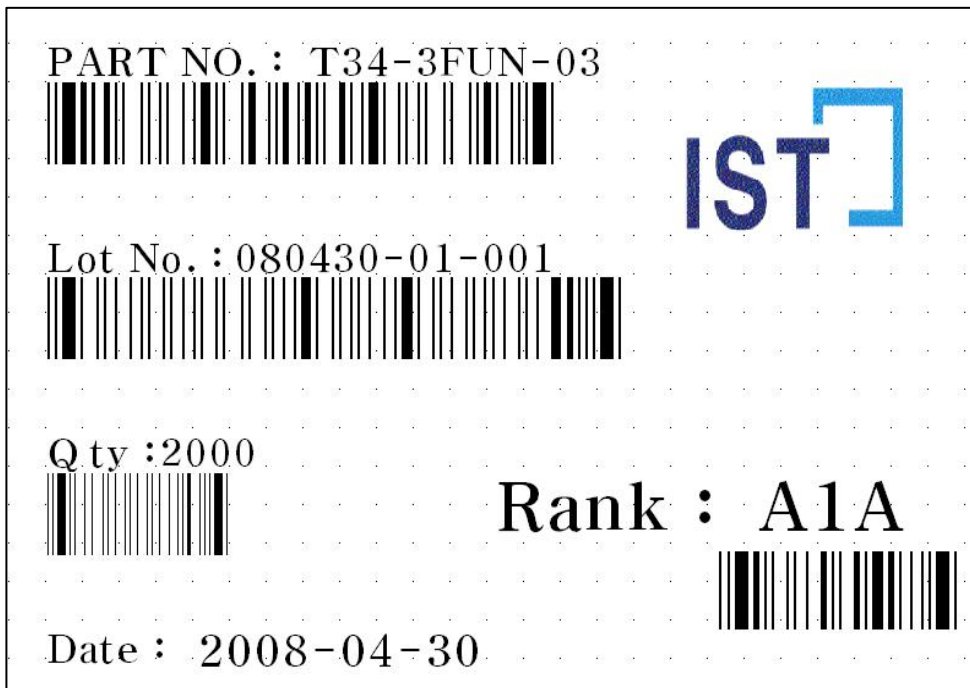
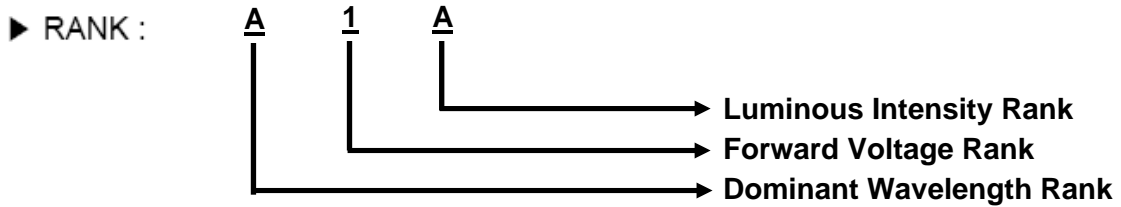

## 13. Precaution For Use

### 1) Storage

In order to avoid the absorption of moisture, it is recommended to store in a dry box (or a desiccator) with a desiccant. Otherwise, to store them in the following environment is recommended.

Temperature : 5 °C ~ 30 °C Humidity : maxim 65%RH

### 2) Attention after open.

LED is correspond to SMD, when LED be soldered dip, interfacial separation may affect the light transmission efficiency, causing the light intensity to drop. Attention in followed;

a. After opened and mounted the soldering shall be quickly.

b. Keeping of a fraction

Temperature : 5 ~ 40 °C Humidity : less than 30%

3) It is recommended that user should complete the use of the whole package within 48 hours upon unsealing. In the event of incomplete usage, It is advised that user preheat the remaining devices at 60±5 °C for 10-12hours prior to use.

4) Any mechanical force or any excess vibration shall not be accepted to apply during cooling process to normal temperature after soldering.

5) Quick cooling shall be avoided.

6) Components shall not be mounted on wrapped direction of PCB.

7) Anti radioactive ray design is not considered for the products.

8) This device should not be used in any type of fluid such as water, oil, organic solvent, etc.  
When washing is required, IPA should be used.

9) When the LEDs are illuminating, operating current should be decided after considering the ambient maximum temperature.

10) LEDs must be stored to maintain a clean atmosphere.

If the LEDs are stored for 3months or more after being shipped from IST, a sealed container with a nitrogen atmosphere should be used for storage.

11) The LEDs must be used within one day after opening the moisture proof packing. Repack unused products with anti-moisture packing, fold to close any opening and then store in a dry place.

12) Repack unused products with one day after opening the moisture-proof packing.

13) The appearance and specifications of the product may be modified for improvement without notice.