

**Harvatek Surface Mount CHIP LED Data Sheet
HT-193NG-KA42**

Official Product	HT Part No. HT-193NG-KA42		
Tentative Product	*****	*****	
Specifications are subject to change without notice. Data and drawings herein are copyrighted.	05/19/2015	Version 1.3	Page 1/14

DISCLAIMER..... 3

PRODUCT SPECIFICATIONS..... 4

ATTENTION: ELECTROSTATIC DISCHARGE (ESD) PROTECTION4

LABEL SPECIFICATIONS..... 5

PRODUCT SPECIFICATIONS..... 6

PRODUCT FEATURES 7

ELECTRO-OPTICAL CHARACTERISTICS.....7

PACKAGE OUTLINE DIMENSION AND RECOMMENDED SOLDERING PATTERN FOR REFLOW

SOLDERING7

ABSOLUTE MAXIMUM RATINGS7

PRECAUTION FOR USE8

CHARACTERISTICS OF B1931NG9

PACKAGING 10

TAPE DIMENSION10

REEL DIMENSION.....11

PACKING11

DRY PACK..... 12

PRECAUTIONS..... 12

REFLOW SOLDERING 13

REWORKING.....13

CLEANING13

REVISE HISTORY.....14

Official Product	HT Part No. HT-193NG-KA42		
Tentative Product	*****	*****	
Specifications are subject to change without notice. Data and drawings herein are copyrighted.	05/19/2015	Version 1.3	Page 2/14

DISCLAIMER

HARVATEK reserves the right to make changes without further notice to any products herein to improve reliability, function or design. HARVATEK does not assume any liability arising out of the application or use of any product or circuit described herein; neither does it convey any license under its patent rights, nor the rights of others.

LIFE SUPPORT POLICY

HARVATEK's products are not authorized for use as critical components in life support devices or systems without the express written approval of the President of HARVATEK or HARVATEK INTERNATIONAL. As used herein:

1. Life support devices or systems are devices or systems which, (a) are intended for surgical implant into the body, or (b) support or sustain life, and (c) whose failure to perform when properly used in accordance with instructions for use provided in the labeling, can be reasonably expected to result in a significant injury of the user.

2. A critical component in any component of a life support device or system whose failure to perform can be reasonably expected to cause the failure of the life support device or system, or to affect its safety or effectiveness.

Official Product	HT Part No. HT-193NG-KA42		
Tentative Product	*****	*****	
Specifications are subject to change without notice. Data and drawings herein are copyrighted.	05/19/2015	Version 1.3	Page 3/14

Product Specifications

	Specification	Material	Quantity
Luminous Intensity(Iv)	NG:180.0-360.0 mcd @20mA/ Ta= 25 ^o ;Tolerance: ± 10%		
Wavelength	NG:520.0-535.0 nm @20mA/ Ta= 25 ^o C;Tolerance: ± 0.5nm		
Vf	NG:2.7-3.9 V(0.1V/BIN) @20mA/ Ta= 25 ^o C ;Tolerance: ± 0.05V		
Ir	< 100 μA @ V _R = 5 V		
Resin	Diffused	Epoxy resin	
Carrier tape	EIA 481-1A specs	Conductive black tape	
Reel	EIA 481-1A specs	Conductive black	
Label	HT standard	Paper	
Packing bag	220x240mm	Aluminum laminated bag/ no-zipper	One reel per bag
Carton	HT standard	Paper	Non-specified

Others:

Each immediate box consists of 5 reels. The 5 reels may not necessarily have the same lot number or the same bin combinations of Iv, λ_D and Vf. Each reel has a label identifying its specification; the immediate box consists of a product label as well.

Note :This is shipped test conditions

※Remarks: This product should be operated in forward bias. If a reverse voltage is continuously applied to the product, such operation can cause migration resulting in LED damage.

ATTENTION: Electrostatic Discharge (ESD) protection



The symbol to the left denotes that ESD precaution is needed. ESD protection for GaP and AlGaAs based chips is necessary even though they are relatively safe in the presence of low static-electric discharge. Parts built with AlInGaP, GaN, or/and InGaN based chips are **STATIC SENSITIVE devices**. ESD precaution must be taken during design and assembly.

If manual work or processing is needed, please ensure the device is adequately protected from ESD during the process.

Official Product	HT Part No. HT-193NG-KA42		
Tentative Product	*****	*****	
Specifications are subject to change without notice. Data and drawings herein are copyrighted.	05/19/2015	Version 1.3	Page 4/14

Label Specifications

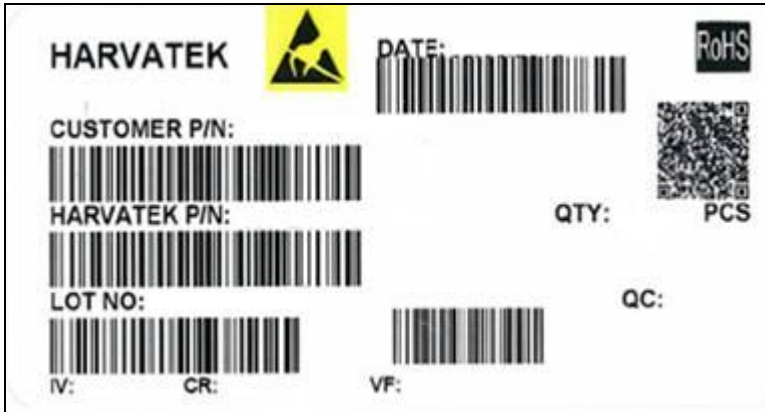

■ Customer P/N: To Be Defined:

HT-193 NG - KA42

Series Name	Emitting Color	Customer Code
HT-193 1.6(L)x0.8(W)x0.4(H) mm	NG Green @20mA	Customer Product Code KA42

■ Lot No.:

1	2	3	4	5	6	7	8	9	10
E	1	A	1	A	2	2	L	1	2
Code 1 2		Code 3	Code 4	Code 5	Code 6	Code 7	Code 8	Code 9	Code 10
		Mfg. Year	Mfg. Month	Mfg. Date	Consecutive number		Special code		
Internal Tracing Code		2010-A 2011-B 2012-C 2013-D . .	1:Jan. 2:Feb. A:Oct. B:Nov. C:Dec.	1:A 2:B 3:C ... 26:Z 27:7 28:8 29:9 30:3 31:4	01~ZZ		000~ZZZ		

Official Product	HT Part No. HT-193NG-KA42		
Tentative Product	*****	*****	
Specifications are subject to change without notice. Data and drawings herein are copyrighted.	05/19/2015	Version 1.3	Page 5/14

Product specifications

■ Luminous Intensity (Iv) Bin:

Color	Bin Code	Spec. Range
NG	S	180.0-285.0 mcd
	T	285.0-360.0 mcd

Note: It maintains a tolerance of $\pm 10\%$ on Luminous Intensity

■ Color Bin:

Color	Bin Code	Spec. Range
NG	B	520-525 nm
	C	525-530 nm
	D	530-535 nm

Note: It maintains a tolerance of $\pm 0.5\text{nm}$ on Color Bin

■ Forward Voltage (Vf) Bin:

Color	Bin Code	Spec. Range
NG	G4	2.7-2.8V
	H1	2.8-2.9 V
	H2	2.9-3.0 V
	H3	3.0-3.1 V
	H4	3.1-3.2 V
	J1	3.2-3.3 V
	J2	3.3-3.4 V
	J3	3.4-3.5 V
	J4	3.5-3.6V
	K1	3.6-3.7V
	K2	3.7-3.8V
	K3	3.8-3.9V

Note: It maintains a tolerance of $\pm 0.05\text{V}$ on forward voltage measurements

Official Product	HT Part No. HT-193NG-KA42		
Tentative Product	*****	*****	
Specifications are subject to change without notice. Data and drawings herein are copyrighted.	05/19/2015	Version 1.3	Page 6/14

Product Features

Electro-Optical Characteristics

(T_{Soldering} 25 °C)

Series	Emitting Color	Material	V _F (V)		Wavelength λ(nm)			I _V (mcd)	Viewing Angle $2\theta \frac{1}{2}$
			typ	max	λ _D	λ _P	Δ λ	Typical	
HT-193NG-KA42	NG	InGaN	3.3	3.9	525	520	30	285.0	X=125 Y=135

Package Outline Dimension and Recommended Soldering Pattern for Reflow Soldering

Unit: mm Tolerance: +/-0.1

Outline Dim.	Soldering Pattern
<p>Cathode side</p> <p>LED Die</p> <p>Pin1</p> <p>Pin2</p> <p>1.6</p> <p>0.8</p> <p>0.40</p> <p>0.17</p> <p>1.00</p> <p>Resin</p> <p>PCB</p> <p>0.75</p> <p>0.38</p> <p>0.40</p> <p>Cathode side</p> <p>Pin1</p> <p>Pin2</p> <p>Polarity</p>	<p>Pin1</p> <p>0.80</p> <p>0.80</p> <p>0.80</p> <p>0.75</p> <p>Pin2</p> <p>Polarity</p>
Soldering terminals may shift in the x, y direction.	

Absolute Maximum Ratings

(T_a 25 °C)

Series	P _D (mW)	V _R (V)	I _F (mA)	I _{FP} (mA)*	T _{OP} (°C)	T _{ST} (°C)
Color	Power Dissipation	Reverse Voltage	Forward Current	Pulse Forward Current	Operating Temperature	Storage Temperature
NG	78	5	20	60	-40~+85	-40~+100

*Condition for I_{FP} is pulse of 1/10 duty and 0.1msec width

Official Product	HT Part No. HT-193NG-KA42		
Tentative Product	*****	*****	
Specifications are subject to change without notice. Data and drawings herein are copyrighted.	05/19/2015	Version 1.3	Page 7/14

Precaution for Use

1. The chips should not be used directly in any type of fluid such as water, oil, organic solvent, etc.
2. When the LEDs are illuminating, the maximum ambient temperature should be first considered before operation.
3. LEDs must be stored in a clean environment. A sealed container with a nitrogen atmosphere is necessary if the storage period is over 3 months after shipping.
4. The LEDs must be used within 4 weeks after unpacked. Unused products must be repacked in an anti-electrostatic package, folded to close any opening and then stored in a dry and cool space.
5. The appearance and specifications of the products may be modified for improvement without further notice.
6. The LEDs are sensitive to the static electricity and surge. It is strongly recommended to use a grounded wrist band and anti-electrostatic glove when handling the LEDs. If a voltage over the absolute maximum rating is applied to LEDs, it will damage LEDs. Damaged LEDs will show some abnormal characteristics such as remarkable increase of leak current, lower turn-on voltage and getting unlit at low current.

Official Product	HT Part No. HT-193NG-KA42		
Tentative Product	*****	*****	
Specifications are subject to change without notice. Data and drawings herein are copyrighted.	05/19/2015	Version 1.3	Page 8/14

Characteristics of B1931NG

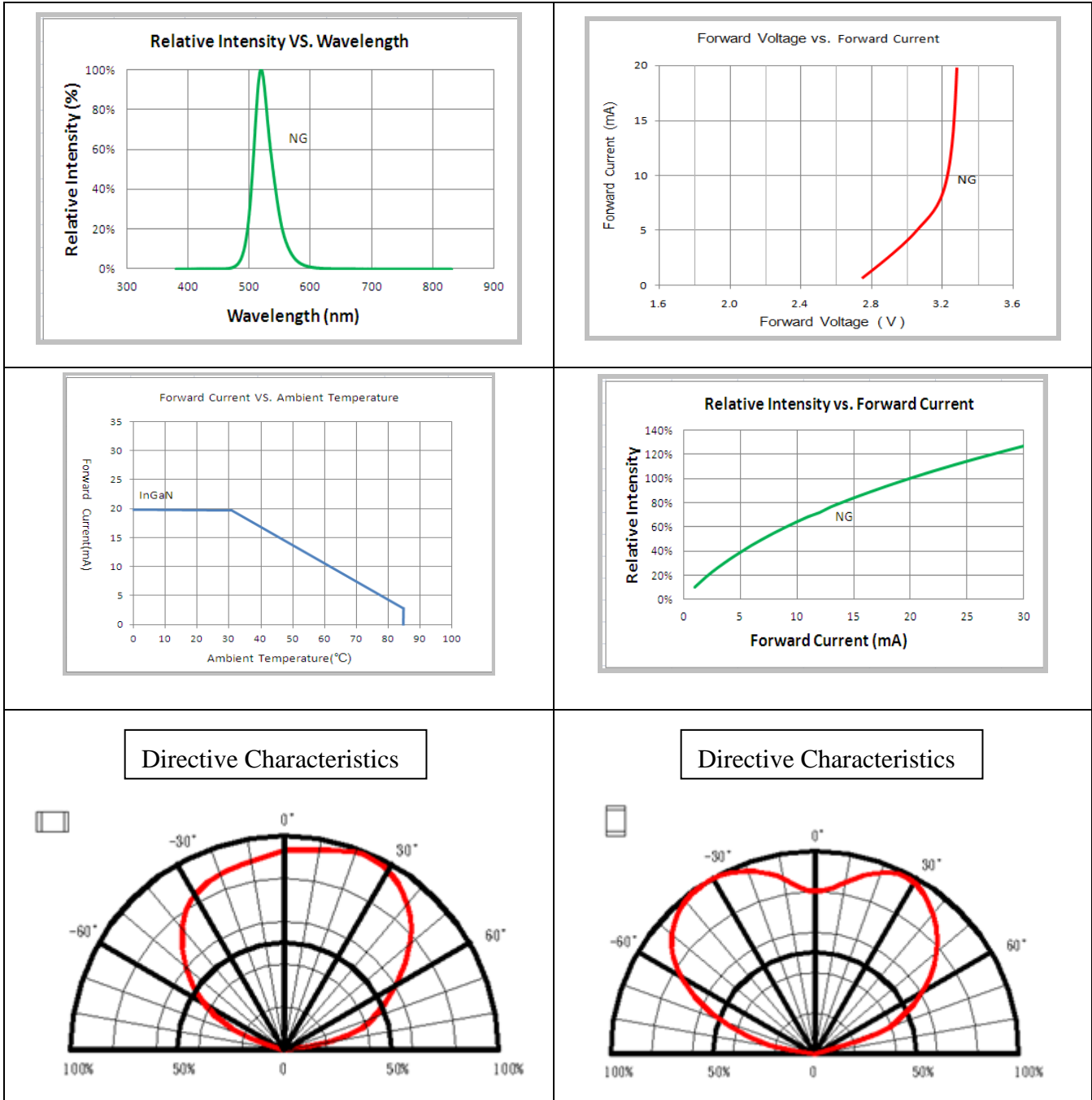

Official Product	HT Part No. HT-193NG-KA42		
Tentative Product	*****	*****	
Specifications are subject to change without notice. Data and drawings herein are copyrighted.	05/19/2015	Version 1.3	Page 9/14

Packaging
Tape Dimension

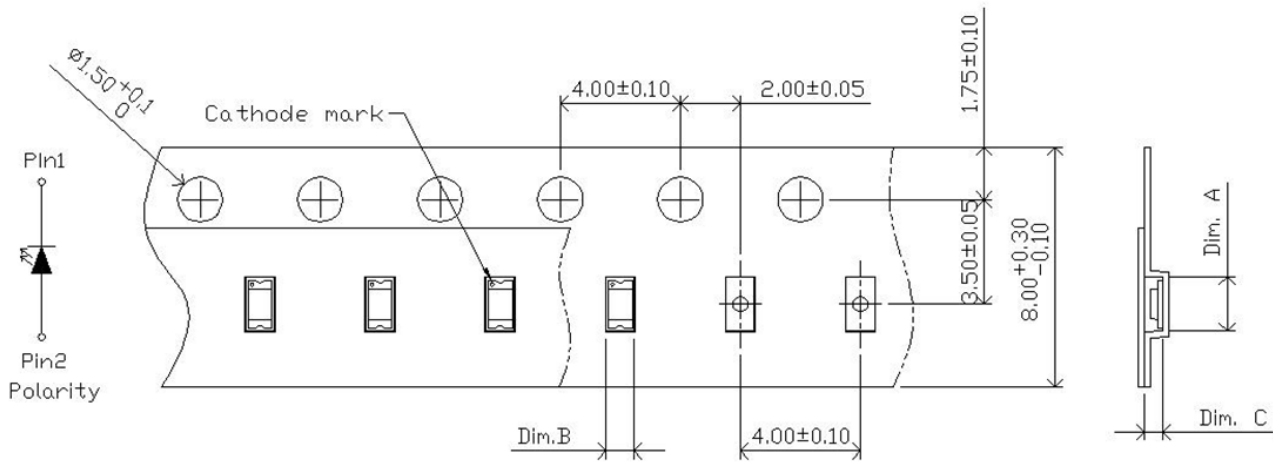

Dim. A	Dim. B	Dim. C	Q'ty/Reel
1.80±0.50	0.94±0.50	0.60±0.50	4K

Unit: mm

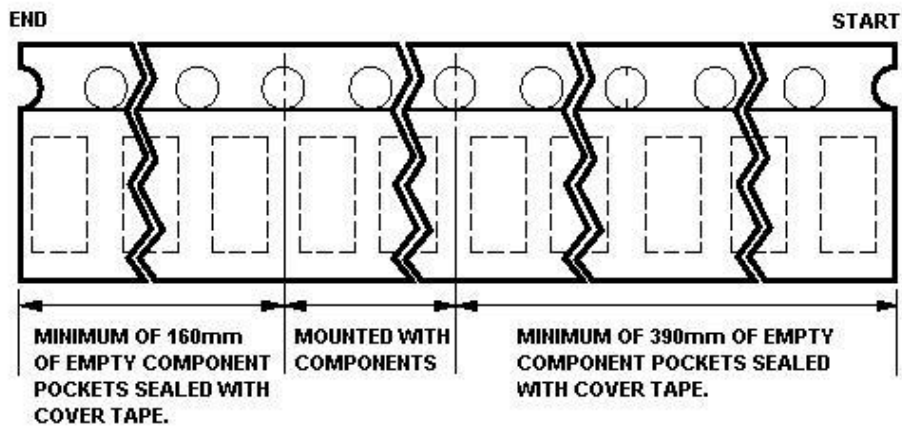

Official Product	HT Part No. HT-193NG-KA42		
Tentative Product	*****	*****	
Specifications are subject to change without notice. Data and drawings herein are copyrighted.	05/19/2015	Version 1.3	Page 10/14

Reel Dimension

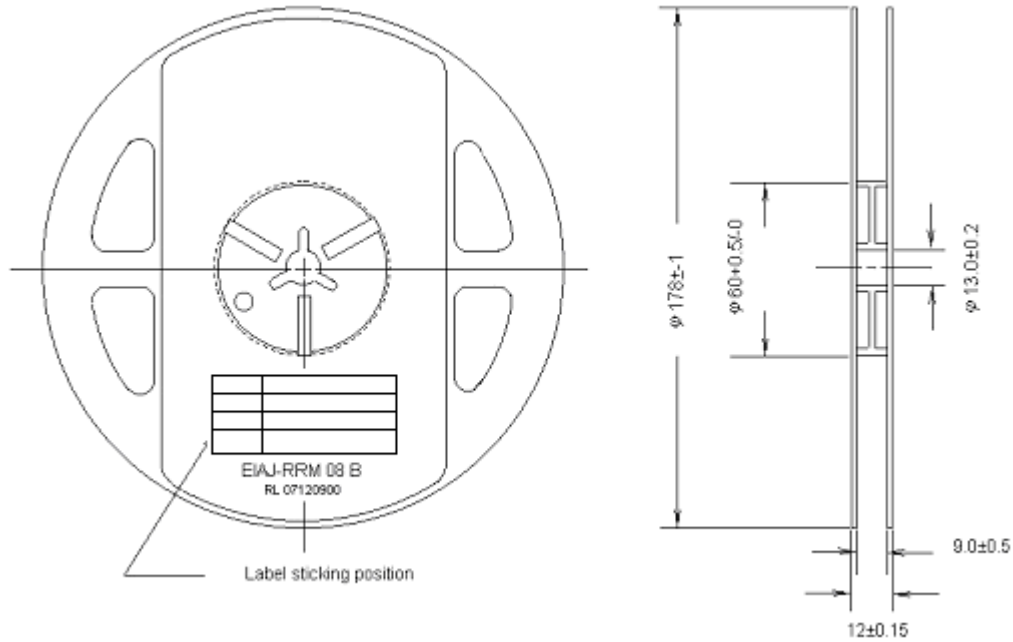

Packing

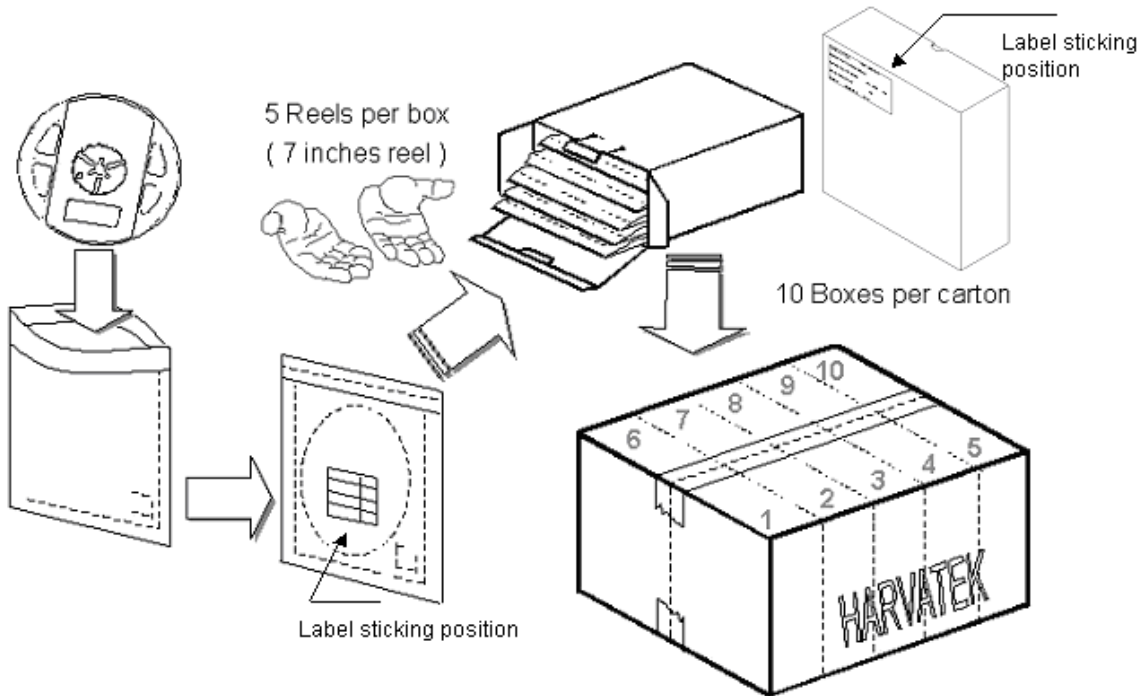

5 boxes per carton is available depending on shipment quantity.

Official Product	HT Part No. HT-193NG-KA42		
Tentative Product	*****	*****	
Specifications are subject to change without notice. Data and drawings herein are copyrighted.	05/19/2015	Version 1.3	Page 11/14

Dry Pack

All SMD optical devices are **MOISTURE SENSITIVE**. Avoid exposure to moisture at all times during transportation or storage. Every reel is packaged in a moisture protected anti-static bag. Each bag is properly sealed prior to shipment.

A humidity indicator will be included in the moisture protected anti-static bag prior to shipment.

The packaging sequence is as follows:

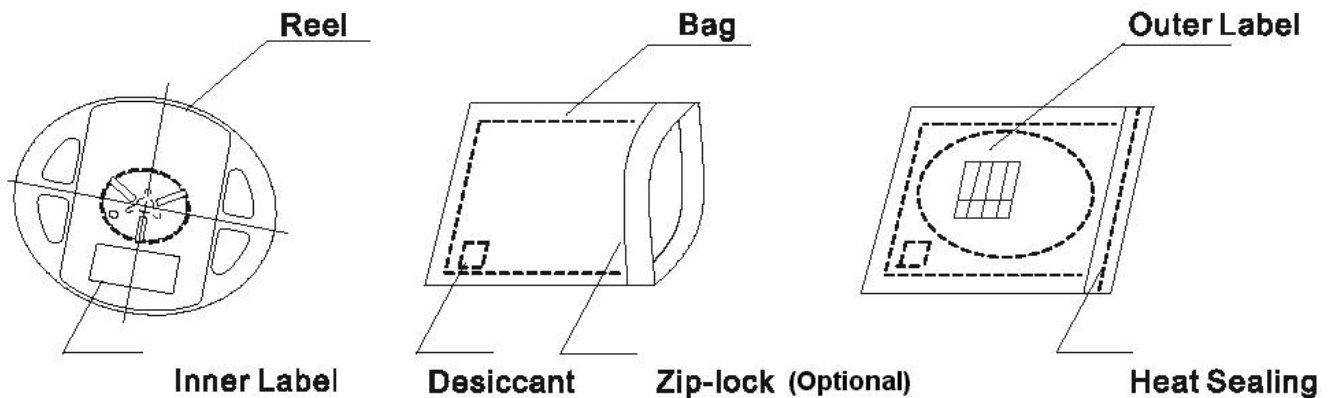

PRECAUTIONS

1. Avoid exposure to moisture at all times during transportation or storage.
2. Anti-Static precaution must be taken when handling GaN, InGaN, and AlInGaP products.
3. It is suggested to connect the unit with a current limiting resistor of the proper size. Avoid applying a reverse voltage beyond the specified limit.
4. Avoid operation beyond the limits as specified by the absolute maximum ratings.
5. Avoid direct contact with the surface through which the LED emits light.
6. If possible, assemble the unit in a clean room or dust-free environment.

Official Product	HT Part No. HT-193NG-KA42		
Tentative Product	*****	*****	
Specifications are subject to change without notice. Data and drawings herein are copyrighted.	05/19/2015	Version 1.3	Page 12/14

Reflow Soldering

Recommend soldering paste specifications:

1. Operating temp.: Above 220 °C ,60 sec.
2. Peak temp.:260 °CMax.,10sec Max.
3. Never attempt next process until the component is cooled down to room temperature after reflow.
4. The recommended reflow soldering profile (measured on the surface of the LED terminal) is as following:

Lead-free Solder Profile

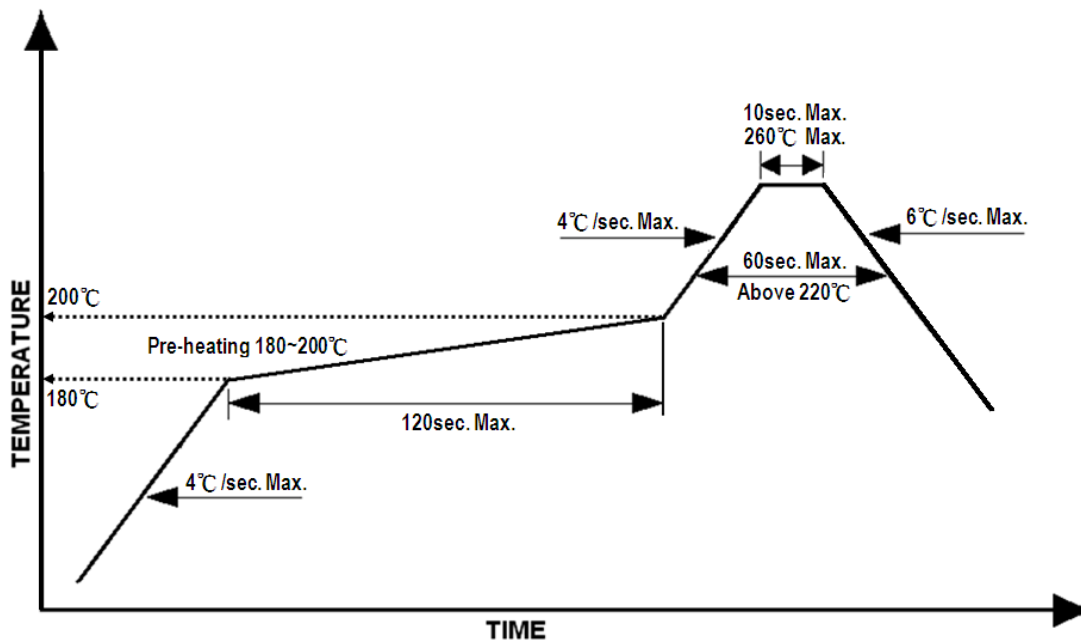

Reworking

- Rework should be completed within 5 seconds under 260 °C.
- The iron tip must not come in contact with the copper foil.
- Twin-head type is preferred.

Cleaning

Following are cleaning procedures after soldering:

- An alcohol-based solvent such as isopropyl alcohol (IPA) is recommended.
- Temperature x Time should be 50°C x 30sec. or <30°C x 3min
- Ultrasonic cleaning: < 15W/ bath; bath volume ≤ 1liter
- Curing: 100 °C max, <3min

Official Product	HT Part No. HT-193NG-KA42		
Tentative Product	*****	*****	
Specifications are subject to change without notice. Data and drawings herein are copyrighted.	05/19/2015	Version 1.3	Page 13/14

